

AQUAPHOR®

water filters

AQUAPHOR RO-70S

DRINKING WATER MACHINE

Owner's manual

RO – A new category of household appliance that allows you to obtain premium drinking water.

AQUAPHOR RO – A combination of the world's best achievements in water treatment and AQUAPHOR technologies.



Unique ion fiber

Effectively and irreversibly removes heavy metals. Carbon block with AQUALEN™ completely removes chlorine, organic substances and carcinogens.



Absorbs free radicals

DWAY (DOUBLE WAY) is a unique technology of water conditioning and optimization, pH and microelements balance.



STC (Safe To Consume)

Materials are certified for contact with drinking water and food.



Click & Turn

Easy cartridge replacement. Clear and safe maintenance.

1. INTRODUCTION

RO-70S produced in the European Union (Estonia).

RO-70S is designed for additional treatment of drinking water from mechanical and colloidal particles, organic impurities, and, depending on the version, for its mineralization. RO-70S eliminates excessive hardness, foreign flavor, smell and color of water from municipal and local water networks (artesian wells, wells, etc.), while meeting the requirements established by this manual.

The action of RO-70S is based on the transfer of water molecules through a semipermeable membrane by applying pressure exceeding the osmotic pressure.

RO-70S materials are safe, non-toxic and do not release water that is hazardous to human health and the environment.

2. TECHNICAL SPECIFICATIONS

Overall dimensions (length × height × width):	271 × 495 × 190 mm	
The pressure of the water supply system is not less than	0.2 MPa (29 psi)	
Water supply pressure no more than	0.63 MPa (91.37 psi)	
Water temperature	+5...+38 °C (+40...+106 °F)	
The maximum productivity of the reverse osmosis membrane (at a water temperature of + 25 °C (80 °F) and a pressure of 0.4 MPa (76 psi))	for the membrane 50 gal / day	7.6 liters per hour
	for the membrane 100 gal / day	15.2 liters per hour
The ratio of purified water and water entering the drainage (at a water temperature of at least 20 °C (70 °F))	1:4–1:6	
Weight, not more than	6.2 kg (14 pounds)	

3. PRODUCT ASSEMBLY

No.	Description	Qty.	
1	RO-70S housing assembly (1)	1 pc	
2	Cartridges (Fig. 1):	1 pc	
	The replacement filtering cartridge (2)	K3	1 pc
	The membrane cartridge (3)	RO-50S (50 gal/day)	1 pc
	The block of water conditioning (4)	The water conditioning cartridge Aquaphor	1 pc
3	Connecting tubes (Figure 2)		
	tube JG 3/8" (d 9.5 mm, L = 1.2 m) color red	1 pc	
	tube JG 1/4" (d 6.35 mm, L = 1.2 m), drainage, color black	1 pc	
	tube JG 1/4" (d 6.35 mm, L = 0.17 m), color blue	1 pc	
	tube JG 1/4" (d 6.35 mm, L = 1 m) with pressed metal sleeve, tube color blue	1 pc	
4	Connection node (Fig. 3)	1 set	
5	Drain saddle (Fig. 5)	1 set	
6	Clean water tap (Fig. 4)	1 set	
7	Bracket for conditioning cartridge with self-tapping screw (Fig. 7a, 7b)	1 set	
8	Insert slit (Fig. 6)	3 pcs	
9	Service plug (Fig. 9)	1 pc	
10	JG tube key (inserted under the cover together with the service plug and slotted inserts)	1 pc	
11	Operating manual	1 pc	

4. THE DEVICE AND PRINCIPLE OF OPERATION RO-70S

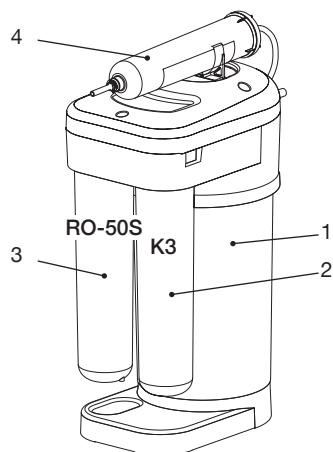

The main components of RO-70S:

- 1 - Housing RO-70S assembly;
- 2 - Preliminary water treatment unit (cartridge K3);
- 3 - Reverse osmosis membrane unit (cartridge RO-50S);
- 4 - Water conditioning unit (cartridge for potting or conditioning of water).

Figure 1

ATTENTION! The efficiency of the RO-70S depends on the pressure of the water supply. Reliable operation of the RO-70S at a pressure in the water pipes of less than 0.2 MPa (29 psi) is not guaranteed.

1. Under reduced pressure in the water supply system, to obtain the optimum drainage ratio and clean water it is recommended to use a pressure boost kit.

The RO-70S housing (1) consists of an upper plate in which two collectors are fixed for connection of the replacement cartridges and hydro automatics of RO-70S. The top plate is covered with a decorative lid fixed by three plastic fasteners.

On this decorative lid a post-filter-filter is fixed. An important part of the RO-70S enclosure is the storage tank for clean water. Since the performance of the membrane cartridge is small (depends on the type of membrane element, water temperature and pressure in the water pipe), the water after the membrane cartridge is fed to the storage tank so that you can use clean water at any time and in the desired quantities.

2. The prefilter unit (2) includes a plug-in filter cartridge K3. The pre-water treatment unit is designed to remove impurities from water that can contaminate the membrane, such as iron hydroxide and active chlorine.

3. The block of membrane (3) enters the reverse osmosis membrane RO-50S. The block of reverse osmosis membrane cleans water from organic and inorganic compounds, salts, and also softens water.

4. The water conditioning unit (4) includes a post-filtration cartridge or a water conditioning cartridge Aquaphor (hereinafter – post-filter) depending on the RO-70S version. The water conditioning unit removes extraneous smell and taste, and, depending on the performance, mineralizes the water.

How the RO-70S works

From the cold water supply network, water enters the RO-70S inlet and passes through a pre-filter. Further, through the automatic valve, water enters the reverse osmosis membrane unit. The membrane cartridge has two outputs: a clean water outlet and a drainage water outlet. Passing through the flow restrictor, drainage water goes to the sewer.

Purified water enters the storage tank, which has a built-in diaphragm separating the tank from into two cavities: accumulative and technical. In the storage cavity there is completely purified drinking water, and in the technical – tap water. During the collection of clean water in the storage tank of the system, tap water from the technical cavity is forced into the drainage, without creating resistance to a set of clean water. As soon as the storage tank is full, the automatic valve will block the flow of water into the RO-70S. Once the storage tank is full, the automatic valve will block the flow of water into the RO-70S.

When you open the tap for pure water, the tap water enters to the technical cavity through the inlet valve and squeezes the purified water out of the storage cavity through the water conditioning unit to the tap for clean water.

This action activates the automatic valve and opens the water supply to the RO-70S storage tank.

5. INSTALLING RO-70S

ATTENTION! Installation of RO-70S must be performed by specialists authorized to carry out this type of work.

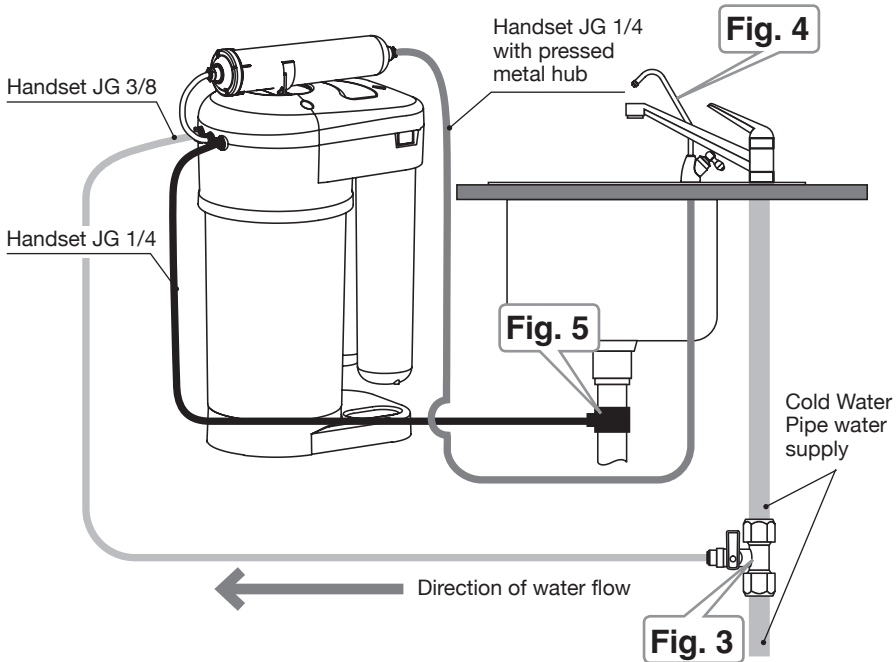

Figure 2

Determine a convenient location of the faucet for clean water and the RO-70S. Pay attention to the fact that the supply tubes must pass freely, without loops or kinks (fig. 2).

The RO-70S must be installed on a flat, sturdy surface (installation on an uneven surface may result in vibration or noise).

RO-70S should be distanced or isolated from heat sources (cookers, boilers, hot water pipes, dishwashers or washing machines, etc.).

Installation of the connection node* (fig. 3)

- Shut off the cold water.
- Open the kitchen faucet to relieve pressure in the water supply.
- Connect the cold water supply water connection.
- Connect the red JG tube. For this, pull out from under the plastic bushing stopper-clip, insert the pre-soaked end of the tube into the sleeve of the union up to the stop to a depth of approximately 20 mm and reinstall the clip.
- Check the strength of the tube fastening:

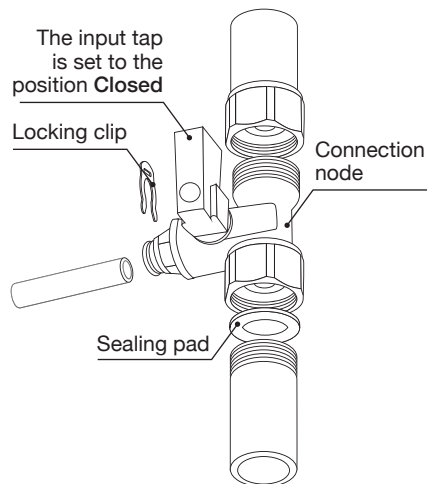

Figure 3

* The manufacturer reserves the right to use the connection points and faucet of a similar design. If necessary, contact the after-sales service.

- At an effort of 8–10 kgf, the tube should not be able to be pulled out.
- Set the input valve to the position **Closed**.
- Open the water from the main line.

Important! Make sure that the sealing pad was on its own place and was not damaged during installation of the connection node.

Installation of the faucet for clean water* (fig. 4)

- Drill a 12 mm hole in the sink (countertop).
- Put the decorative stand (2), the rubber gasket (3), the rubber washer (4) on the threaded shank (1) of the faucet and insert the tap into the wash hole.
- Place the plastic washer (5), the metal lock washer (6) on the threaded shank from the bottom of the countertop and screw the fastening nut (7).
- Insert the tube (9) into the threaded shank of the tap (1) with the end of the pressed metal sleeve and tighten the union nut (8) until it stops;
- Check the strength of the tube (9). The tube should not be able to be pulled out when using a force of 8–10 kgf.

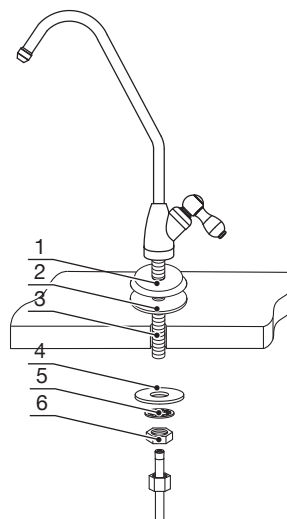

Figure 4

Attention! We recommend that you use the clean water faucet included with this product. The use of other faucets can lead to vibrations and other extraneous sounds.

Drain saddle installation (fig. 5)

- It is the best install the drain saddle on the sink drain before the siphon trap or bend (the drain saddle on most drain pipes is of ~40 mm diameter).
- Remove the protective film (2) from the gasket (1). Glue (or fasten) the sealing gasket (1) from the inside of the clamp so that the hole in the gasket matches the hole in the saddle union.
- Install the saddle on the drain line and then tighten the bolts (3). Bolts should be tightened evenly, so that the two parts of the yoke are parallel.
- Drill a hole 7 mm in diameter through the hose connection.
- On the JG drain tube, put on the plastic nut and, inserting the tube into the drainage collar, screw the nut onto the nipple.

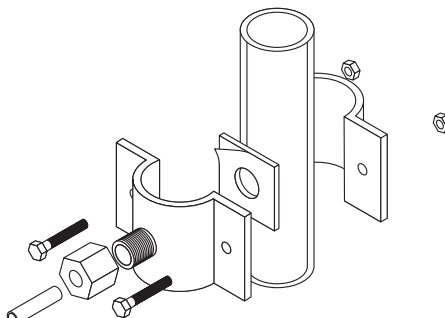

Figure 5

Installing the crevice insert** (fig. 6)

- Remove the crevice insert, which is under the cover of the water purifier. In order to remove the cover, it is necessary to turn the three latches counter-clockwise.
- Insert the crevice insert into the 3/8" (9.5 mm) tube as shown in fig. 6 and connect this end of the tube to the water cleaner.

Attention! The kit includes three inserts: one for the installation, two are spares.

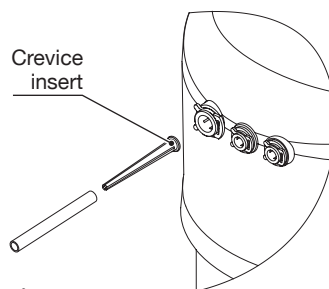

Figure 6

* The manufacturer reserves the right to use the connection points and faucet of a similar design. If necessary, contact the after-sales service.

** The crevice insert is installed only for the water with a high content of mechanical impurities in the water.

Installation of the water conditioning cartridge (fig. 7)

- Install the bracket for the conditioning cartridge on the RO-70S trim cover and secure it with a self-tapping screw, as shown in fig. 7a.
- Before connecting the post-filter, remove the transport plugs installed in the JG sockets at the input and during the post-filter (see the Disconnection of the JG tubes).
- Place the post-filter in the bracket by pressing on the post-filter, as shown in fig. 7b.

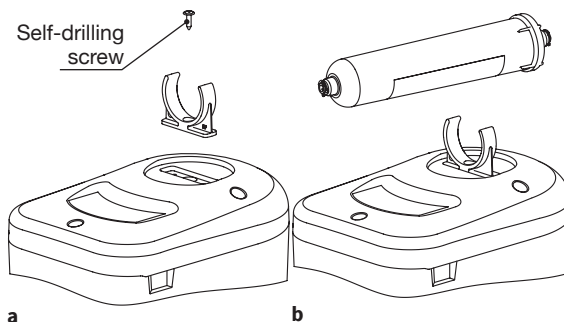

Figure 7

Connect the JG 1/4" blue (d 6.35 mm) L = 0.17 m inlet fitting (fig. 13) to the RO-70S body in accordance with the diagram (fig. 2).

6. STARTING RO-70S

To start the RO-70S, it is necessary to connect the supply pipes and carry out the procedure for rinsing the cartridges and the membrane.

Step 1. Connect the supply pipes by following the diagrams below.

The connection diagram of the tubes is shown in fig. 2.

Connection of JG tubes

Pull the locking clip (2) out from under the plastic sleeve (1), insert the pre-wetted end of the tube (3) into the sleeve bushing to a depth of approximately 15 mm to the stop and install the clip (2) into place. Check the strength of the tube (3): at an effort of 8–10 kg, the tube should not be able to be pulled out.

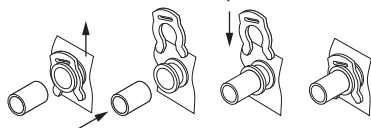

Disconnection of JG tubes

Pull the locking clip (2) out from under the plastic sleeve (1) and pull the tube (3) by pressing the end of the plastic sleeve. For depressing, use the wrench (4) to disconnect the tubes that is included in the water purifier kit.

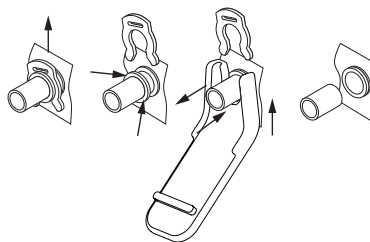

Step 2. Preparation of the water purifier for operation

- Remove the lid from the water purifier by turning the three latches anticlockwise by 90 °C (Fig. 8).
- Remove the service plug (fig. 9), which is located under the lid of the water purifier.
- Remove the shrink film from the K3 (K6) cartridge and remove the transport plug (if any).
- Moisten the O-rings on the plugs of the cartridges under running water.

For convenience, the stop buttons on the manifolds have a different color. Install the filter cartridge K3 and service plug (fig. 10) in the order indicated in Table 1.

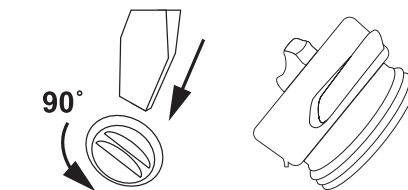

Figure 8

Figure 9

Rinsing of the pre-treatment and conditioning unit

- Set the input tap to the **Open**.
- Open the tap for fresh water and wait for water to flow from it. First, air will escape from the system, which may be accompanied by noise.
- Pass water through the water purifier for 10 minutes.
- Close the fresh water faucet and allow the water cleaner to sit for 10 minutes.
- Close the input faucet

Table 1. The position of the cartridges in the RO-70S for the preparation for operation

Color of the lock button	The type of cartridge
BLACK	K3
RED	Service plug

- Flow water again through the water purifier for 30–50 minutes

Step 3. Install the RO-50S membrane cartridge

- In accordance with Table 2, insert each cartridge into the corresponding manifold until it stops and turn it clockwise until it clicks (fig. 11a).
- Connect the drain pipe bracket to the replacement membrane cartridge (for this, insert the pre-wetted end of the square into the drainage sleeve bushing to the stop, see fig. 11b). Install the locking clip.

Table 2. Position of cartridges in RO-70S

Color of the lock button	The type of cartridge
BLACK	K3
RED	Membrane cartridge

Step 4. Rinse the RO-70S

Rinsing of reverse osmosis membrane unit

- Set the input tap on the connection node to the **Open** position.
- Open the faucet for fresh water. Wait for water to flow from it.
- Run water through the RO-70S for 1 hour.*
- Close the fresh water faucet.

Flush the storage tank

- After filling the storage tank (when the water stops coming out of the drain pipe), open the fresh water faucet and wait until all the water has drained out of the storage tank.
- Refill and drain the storage tank.

Note: the procedure for filling the tank twice takes no more than 3 hours.

- Ensure that the RO-70S is sealed.
- After filling the tank, the RO-70S is ready for operation.

ATTENTION! The water obtained during rinsing is not intended for drinking!

Check the RO-70S for leaks during the first week of operation.

In the first week of operation of the RO-70S, when the automatic valve is switched, noise may be observed associated with the release of air from the internal cavities of the RO-70S. After a while, this process will stop. This is not a malfunction.

Depending on the conditions of storage, transportation and operation, the complete rinsing of the membrane cartridge can take no more than 24 hours.

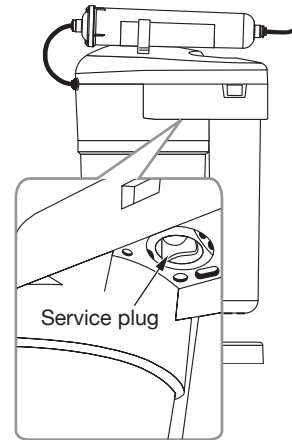

Figure 10

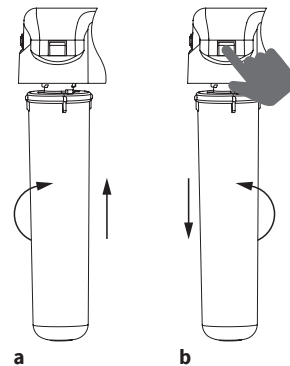

Figure 11

7. REPLACING CARTRIDGES

The service life of the replacement membrane cartridge directly depends on the operability of the pre-treatment unit. Therefore, it is very important to replace the filter cartridge on time.

Replacing the cartridge K3:

- Set the inlet valve on the connection node to the **Closed** position and open the fresh water faucet to relieve pressure.
- Press the stop button all the way down and hold it – then, turn the cartridge counterclockwise and remove it.
- Remove the plastic film from the new cartridge.
- Rinse the cartridge's O-rings under running water.
- Insert the cartridge into the appropriate manifold as far as it will go and, slightly pressing upwards, turn the cartridge clockwise until it clicks.
- Replace the membrane cartridge with the service plug (fig. 10).
- Set the input tap on the connection node to the **Open** position and make sure that the RO-70S is sealed.
- Carry out the procedure “Rinsing the pre-treatment and conditioning unit” (see p. 8).
- Replace the membrane cartridge.
- Set the input valve on the connection node to the **Open** position and make sure that the RO-70S is sealed.

Replacing the membrane cartridge:

- Set the input tap to the **Closed** position and open the faucet for fresh water to release the pressure.
- Press all the way down and hold the locking button, turn the used membrane cartridge counter clockwise and remove it.
- Insert the cartridge into the appropriate manifold as far as it will go and, slightly pressing upwards, turn the cartridge clockwise until it clicks.
- Set the input tap to the **Open** position and make sure that the RO-70S is sealed.
- Perform the procedure “Rinsing the reverse osmosis membrane unit” (see p. 8).

Replacing the conditioning cartridge (fig. 12):

- Set the shutoff valve on the connection node to the **Closed** position; then open the fresh water faucet to relieve pressure.
- Disconnect the JG tube from the inlet and outlet nipples (fig. 12). For this purpose please remove the retaining clip from under the plastic sleeve, press the end of the plastic sleeve and pull out the tube.
- Remove the postfilter from the holder. For this purpose please pull the postfilter up with an effort.
- To install the postfilter, perform the same steps in reverse order. Before installing the postfilter, do not forget to remove the transport plugs (see paragraph “Installing the postfilter”).
- Perform the procedure “Flushing Preliminary water treatment and conditioning block” (see p. 8).

Slotted plug replacement:

- Set the inlet valve on the connection node to the Closed position and open the fresh water faucet to relieve pressure.
- Remove the slotted plug from the tube (fig. 6).
- Replace the slotted plug with a new one or flush installed slotted plug under cold water.
- If the slotted plug clogs more often than the cartridges of the preliminary water treatment block, we recommend to install an additional step of mechanical water purification, for example, the Prefilter Aquaphor for cold water.
- Washing procedure is not required.

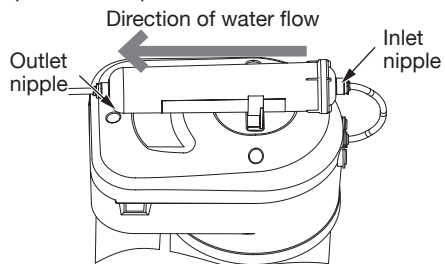

Figure 12

9. SECURITY

RO-70S is designed for post-treatment and water softening, corresponding to national standards.

When installing RO-70S outside the central drinking water supply system, it is recommended that the source water be analyzed for compliance with national standards

- If the source water does not meet the requirements of national standards, the service life of the prefiltration unit and the reverse osmosis membrane decreases sharply.
- If the source water is significantly different from the requirements of national standards, it is recommended to install additional water treatment systems (iron remover, softener, disinfectant, mechanical filters, etc).

Although the reverse osmosis system can inhibit bacteria and viruses that may be present in the source water, it is recommended to use the system only with water that is microbiologically safe. Do not use a system with water of unknown quality that has not undergone additional disinfection.

Purified water is not subject to long-term storage. We recommend using fresh filtered water.

Use RO-70S only to clean the water from the cold water system.

If you do not plan to use the water purifier for more than 2 days, turn off the water supply to the water purifier (to do this, set the tap on the connection node to the **Closed** position).

When resuming use:

If you did not use the water purifier for more than 2 days, completely drain the water from the tank before use.

If you have not used the water purifier for more than 2 weeks, completely drain before use. Then, empty the tank three times to completely rinse it. After that, you can use the water purifier.

If you have not used RO-70S for more than 4 weeks, perform the full wash cycle according to the instructions in section 6 "Starting the RO-70S" in this manual

ATTENTION! Do not drink water that was obtained during rinsing.

Note! It is not recommended to connect the RO-70S to the water supply network on its own. This work should be carried out by a specialist authorized to carry out this type of work. The manufacturer is not responsible for the inadequate quality of the connection of the RO-70S to the water supply network, as well as for the result of this work. Responsibility for the shortcomings of this work, as well as for causing harm to the health or property of the consumer or other persons due to these shortcomings, is the performer of this work.

It is allowed to use only the faucet and tubes supplied.

When transporting, storing and using the RO-70S, ensure that it is not dropped and that it is free from water. Dispose according to environmental, sanitary and sanitary requirements, established by national and local standards in the field of environmental protection and ensuring the sanitary and epidemiological welfare of the population.

10. WARRANTY

Installation, operational, storage and transportation rules described in this manual should be maintained. The manufacturer is not responsible for operation of the Aquaphor RO and possible consequences, in case if:

- RO or components have visible mechanical, thermal or chemical damages;
- requirements for installation and operation of the RO described in the manual were not carried out.
- The lifetime of the RO components is:
- RO case – 5 years* starting from the manufacturing date;
- Connecting pipes – 3 years* starting from the manufacturing date;
- Purified water faucet – 3 years* starting from the manufacturing date.
- The lifetime (capacity) of the replacement filter cartridges is:

Name of the replacement filter cartridge	Lifetime (capacity) of the replacement filter cartridge
K3	3 months*
Membrane cartridge Aquaphor RO-50S	not more than 2 years 1,5 years**
Conditioning cartridge	1 year

* Depending on the amount of impurities in the water, the service life (resource) of the water treatment cartridges may vary (may be shorter or longer than the standard service life).

** Service life of membrane element is directly dependent on the operation of pre-treatment cartridges. Please replace filter cartridges timely.

Aquaphor Water Filters products are backed by some of the most comprehensive warranties in the industry. Aquaphor warrants that the Aquaphor water filtration system shall be free from material defects and workmanship under normal use and service.

Aquaphor RO – One Year Warranty.

100% coverage of all parts and labor for the entire product for the first year from original date of purchase.

This does not apply, however, to consumable filters.

Exclusions and Limitations

Aquaphor warrants its products to be free from manufacturing defects under normal use and service. This warranty is extended only to the ORIGINAL PURCHASER.

Aquaphor obligations under this warranty are limited to repairs or replacement, at Aquaphor's option, of products or parts found to be defective, provided that such products were properly installed and used in accordance with instructions. Aquaphor reserves the right to make such inspections as may be necessary in order to determine the cause of the defect. Aquaphor will not charge for labor or parts in connection with warranty repairs for the first full year from date of purchase on all products except those that may be subject to commercial use limitations, when applicable.

Aquaphor is not responsible for the cost of removal, return (shipping) and/or reinstallation of products.

This warranty does NOT apply to:

- Damage or loss which occurs during shipment.
- Damage or loss sustained through any natural or man-made causes beyond the control of Aquaphor, including but not limited to fire, earthquake, floods, etc.
- Damage or loss resulting from sediment or foreign matter contained in a water system.
- Damage or loss resulting from negligent or improper installation including installation of a unit in a harsh or hazardous environment.
- Damage or loss resulting from removal, improper repair, modification of the product, or improper maintenance including damage caused by chlorine or chlorine related products.
- Damage or loss resulting from acts which are not the fault of Aquaphor or which the Product is not specified to tolerate.

This warranty gives you specific legal rights. You may have other rights which vary from state to state.

THIS WRITTEN WARRANTY IS THE ONLY WARRANTY MADE BY AQUAPHOR. REPAIR OR REPLACEMENT AS PROVIDED UNDER THIS WARRANTY SHALL BE THE EXCLUSIVE REMEDY AVAILABLE TO THE PURCHASER.

AQUAPHOR SHALL NOT BE RESPONSIBLE FOR LOSS OF USE OF THE PRODUCT OR FOR OTHER INCIDENTAL, SPECIAL, FOR CONSEQUENTIAL DAMAGES OR EXPENSES INCURRED BY THE PURCHASER OR FOR LABOR OR OTHER COSTS DUE TO INSTALLATION OR REMOVAL OR COSTS OF REPAIRS BY OTHERS, OR FOR ANY OTHER EXPENSE NOT SPECIFICALLY STATED ABOVE. EXCEPT TO THE EXTENT PROHIBITED BY APPLICABLE LAW, ANY IMPLIED WARRANTIES, INCLUDING THAT OF MERCHANTABILITY, ARE EXPRESSLY LIMITED TO THE DURATION OF THIS WARRANTY. SOME STATES DO NOT ALLOW LIMITATIONS, SO THE ABOVE LIMITATION AND EXCLUSION MAY NOT APPLY TO YOU.

How to Obtain Service

To obtain repair service under this warranty, you must contact an authorized Aquaphor Service Center to obtain an RMA (Return Merchandise Authorization) number. Proof of purchase in the form of a copy of the original receipt must accompany the returned unit for the warranty to be valid. Take or ship the unit pre-paid to the closest Aquaphor authorized service center along with the RMA number and proof of purchase.

TROUBLESHOOTING TABLE

Malfunction	The cause (wherefore)	Method of elimination
There is no clean water or it is not enough	<p>The cartridge of the preliminary water treatment unit K3</p> <p>The slot insert is jammed</p> <p>The membrane cartridge RO-50S is blocked</p> <p>The plug in cartridge of the water conditioning unit is damaged</p> <p>Defective input valve</p> <p>Closed connection cock</p> <p>Low inlet pressure</p> <p>Foreign object in one of the supply tubes</p>	<p>Replace the cartridge of the preliminary water preparation unit K3.</p> <p>Replace the crevice insert or wash previously installed under a stream of cold water</p> <p>Replace the RO-50S membrane cartridge</p> <p>Replace the water conditioning cartridge</p> <p>Contact the after-sales service</p> <p>Open the connection node tap</p> <p>Install a booster pump for the whole home or specifically for the RO-70S</p> <p>Contact the after-sales service</p> <p>Replace the water conditioning cartridge</p> <p>Contact with your service</p>
The tap water flows slowly	<p>The plug-in cartridge of the water conditioning unit is damaged</p> <p>The pressure in the aqueduct dropped</p>	<p>Replace the water conditioning cartridge</p>
Water constantly flows to the drain	<p>Automatic valve is defective</p>	<p>Contact with your service</p>

Warranty coupon Aquaphor RO-70S

Serial #	
Date of Sell	
Seller's stamp	
Seller's signature	

Please visit our website and register your RO at aquaphor.com/register for manufacturer's warranty.

Installation information

Installation is carried out: Name of the company which carried out installation:	
Name of the service engineer:	
Service engineer's signature:	
Client's signature:	
For installation, operational and technical maintenance, please, contact:	

Manufacturer:

**Westaqua-Invest OÜ division
of Aquaphor Corp., L. Tolstoi 2A,
Sillamäe, Estonia, 40231.
www.aquaphor.com**

AQUAPHOR RO-70S

(Drinking water machine Aquaphor DWM-701S-FM)

**Serial#, date of manufacturing
and quality control:**